

SUBMERSIBLE GRINDER PUMP

Series: CPG
3, 5 & 7.5 HP
3500 RPM
Discharge: 2"



2" NPT, Vertical



2.5" Flange, Horizontal

DISCHARGE

2" NPT, vertical.

LIQUID TEMPERATURE

104 °F (40 °C).

VOLUTE

Cast iron ASTM A-48, class 30.

MOTOR HOUSING

Cast iron ASTM A-48, class 30.

SEAL PLATE

Cast iron ASTM A-48, class 30.

IMPELLER

Design: 10 vanes, vortex with vanes on back side, dynamically balanced.

Material: Cast iron ASTM A-48, class 30.

Radial cutter: hardened 440C, stainless steel, hardness Rockwell C-55.

Shredding ring: hardened 440C, stainless steel, hardness Rockwell C-55.

SHAFT

420 series stainless steel.

SQUARE RINGS

Buna-N.

HARDWARE

Stainless steel.

PAINT

Air dry enamel, water based.

SEAL

Design: double, mechanical, oil lubricated.

Material: silicon carbide outboard, carbon ceramic inboard, Buna-N elastomer and stainless steel hardware.

CORD ENTRY

40 ft of neoprene cord, sealed against moisture.

BEARINGS

Ball, single row, oil lubricated.

MOTOR

Single phase: NEMA L, capacitor start/run (to be located in control panel), 230 volts, 60 Hz, 3500 RPM, oil filled. Class F insulation.

Three phase: NEMA B, 230 & 460 volts, 60 Hz, 3500 RPM, oil filled. Class F insulation.

Requires overload protection to be included in control panel.

MOISTURE SENSOR

Normally open (N/O) included.

OPTIONAL EQUIPMENT

Additional cord, tungsten seal, slide rail coupling

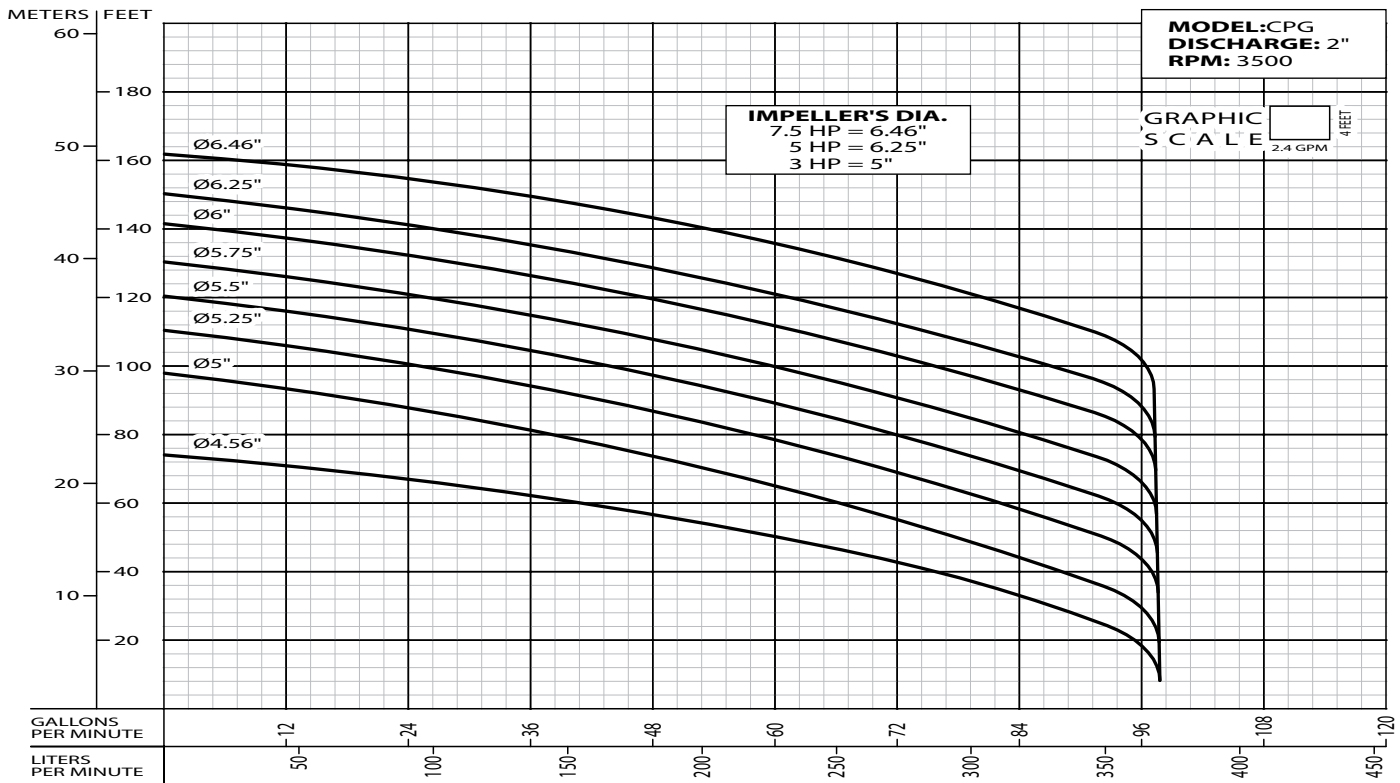
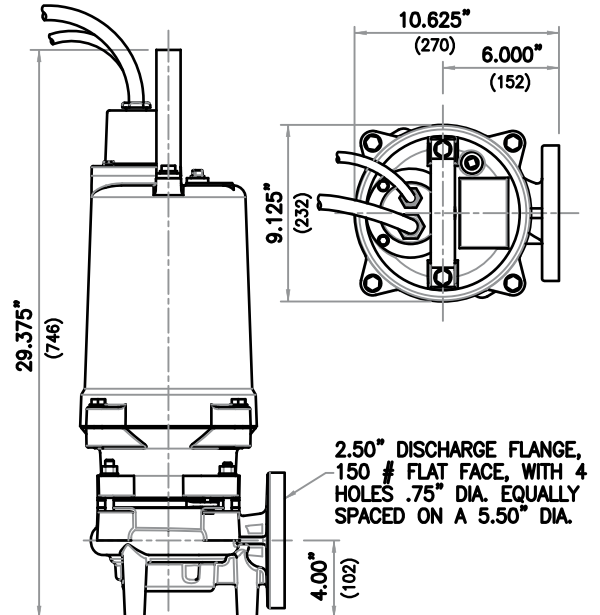
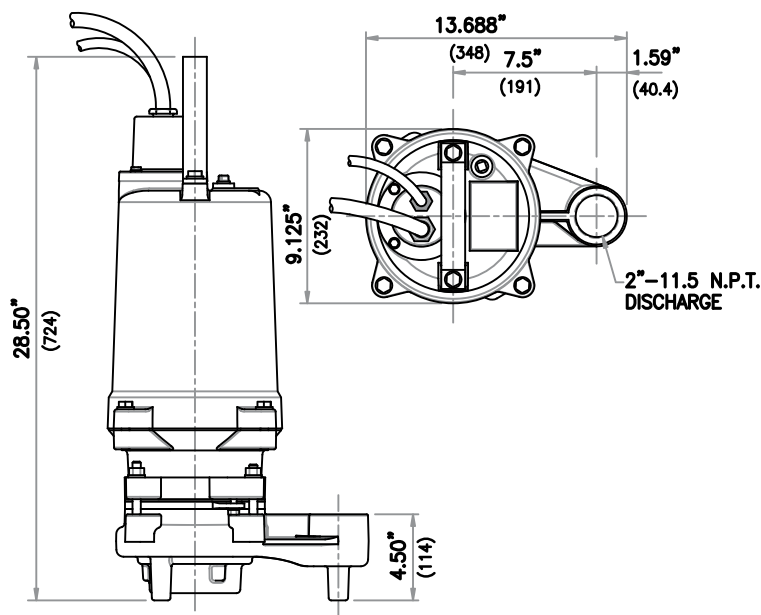

MODEL	HP	VOLTS	PHASE	RPM	MAX AMPS	LOCKED ROTOR AMPS	NEMA CODE	CORD SIZE	CORD TYPE	CORD LENGTH	WEIGHT
CPG3022 (H)	3	230	1	3500	23	75	G	10/4C	SO	40'	188
CPG3062 (H)	3	200	3	3500	20	81.4	L	10/4C	SO	40'	188
CPG3032 (H)	3	230	3	3500	13	56.6	K	10/4C	SO	40'	188
CPG3042 (H)	3	460	3	3500	6.5	28.3	K	10/4C	SO	40'	188
CPG5022 (H)	5	230	1	3500	39	117	H	8/4C	SO	40'	199
CPG5062 (H)	5	200	3	3500	24	102	J	10/4C	SO	40'	199
CPG5032 (H)	5	230	3	3500	20	81.4	L	10/4C	SO	40'	199
CPG5042 (H)	5	460	3	3500	10	40.7	L	10/4C	SO	40'	199
CPG7532 (H)	7.5	230	3	3500	24	102	J	10/4C	SO	40'	203
CPG7542 (H)	7.5	460	3	3500	12	51	J	10/4C	SO	40'	203

IMPORTANT!

1. Never use this pump to handle explosive liquids. 2. This pump is not approved to be used in swimming pools, recreational installations or any application where human contact may be common. 3. Pump may be operated "dry" for extended periods without damage to motor &/or seals. 4. Testing is performed with water specific gravity of 1.0 @ 68 °F (20 °C); other fluids may vary performance.